



Sprayers



User Guide Ranch King Sprayers

Limited Warranty

This Remcor, Inc. product is warranted for one year against defects in materials and workmanship and to perform according to specifications furnished when such products are properly assembled, installed, used and maintained

Should any part prove defective within one year from date of purchase the part will be replaced FOB our factory without charge, providing the part is returned to us, transportation charges prepaid. No allowance will be made for labor, transportation or other charges incurred in the replacement of the defective part. Remcor Inc. will not be responsible for labor charges, loss or damage caused by a defective part. Component parts, equipment, accessories and items not manufactured by Remcor inc. are warranted only to the extent of the original manufacturer's warranty. Consequential damages, if any are specifically excluded from this warranty.

General Instructions

1. Manifold bracket must be attached to the main frame with 1” bolt and locknut. By-pass hose should be attached to return under the tank with hose attached to pressure relief valve.
 2. Breakaway booms should be attached to center boom section using 1 1/4” bolt with locknut at first hole. Slotted breakaway is attached with 1” bolt, one washer and locknut. Breakaway should be loose enough to allow boom to swing back when an object is encountered! Boom chains should be attached to top corners of center section and center hole in boom with 1” bolt and locknut. Boom should be level with ground when boom chains are adjusted.
 3. Boom hose and nozzles should be installed by removing cap and nut from T or L, inserted into appropriate hole in boom, then reassembled. Nut should be tight enough to hold in boom, but nozzle cap should only be finger tight. All nozzle openings should be facing rear of sprayer. Rubber boom straps should be used either to hold boom in transport position or hooked in chain with enough tension to allow boom to float. Boom chain would be loose if properly installed.
 4. Pasture broadcast nozzle, boom and handgun hoses should be run under the tank and be attached to appropriate hose barb on manifold.
 5. Pump hose should be installed with hose running from strainer under the tank to outlet marked “in” on pump. Hose from “out” goes to manifold. Make sure hose length on pump is right distance from your tractor with pump mounted on tractor PTO and lift arms or hitch attached to your tractor. Chain on pump should go around tractor lift arm.
 6. After all accessories are installed, partially fill tank with water and check all hoses and fittings for leaks. You may need to tighten some fittings or hose clamps. Straps should be tightened after filling tank.
 7. Valve at bottom of tank outlet should be open when running pump. Always make sure strainer is clean prior to running sprayer.
 8. Run sprayer using water to familiarize yourself with the operation on various accessories. Recheck for leaks.
 9. Pressure of sprayer is adjusted at pressure relief valve by screwing in for higher pressure, out for lower pressure.
 10. Tank and spray system should be flushed with clear water after use. Chemicals should not be left in tank and system for prolonged periods of time to avoid residual effect. Add anti-freeze to pump when unit is stored for prolonged periods – especially during winter.
 11. If you don’t find the answers call REMCOR at (903) 532-6214.
-
1. For gasoline engines: Check engine and gear reduction for oil and gas.
 2. Partially fill spray tank with water only.
 3. Tighten straps on tank.
 4. Open tank ball valve on suction line to pump.
 5. Open pump pressure relief valve
 6. Start engine and allow to run pump.
 7. Check for leaks – tighten necessary clamps and fittings to eliminate leaks.
 8. Adjust pressure relief valve to obtain desired pressure.
 9. Operate hand gun or boom and check for leaks.
 10. Drain tank, pump, hoses, and strainer after each use. Flush with clear water after each use.
 11. During storage periods put anti-freeze in tank and pull engine rope several times to circulate anti-freeze in pump, strainer, and other fittings. (Any time stored for over 2 weeks)
 12. Engine problems should be referred to Briggs and Stratton service center. Other questions call Remcor at (903) 532-6214

How do I winterize my sprayer?

- 1. Prevent Freeze Damage by Draining your System** - One of the easiest problems to avoid is freeze damage. Simply drain your system - tank, hoses, pump, strainers, etc. Be sure that you loosen check valve diaphragms to ensure more complete drainage. This simple task will protect your equipment from damage caused by freezing.
- 2. Flush Pump After Use** - One of the most common causes for faulty pump performance is "gumming" or corrosion inside the pump. This can be avoided by flushing the pump with a solution that will chemically neutralize the liquid that was pumped. Most residues remaining in the pump will dissolve, leaving the inside of the pump clean for the next use. Flushing is also a good practice for the entire system.
- 3. Use Antifreeze to Prevent Corrosion** - After draining your system and cleaning the pump as directed above, flush with a 50% solution of permanent-type automobile antifreeze (Prestone, Zerex, etc.) containing a rust inhibitor. Plug the ports of the pump to keep out air during storage. This process will coat and protect your spraying components from corrosion.
- 4. Don't Forget About the Spray Tips** - Even though they are one of the smallest parts on a sprayer, spray tips also need to be winterized. Remove spray tips and tip strainers and rinse in water. Tips made of corrosion-prone (metal) materials can be sprayed with a light-weight oil (WD-40 or similar oils). Once dry, store spray tips and strainers in a container to avoid damage from dust and outdoor elements.

Parts Breakdown

25 Gallon Snyder Tank
Part #: 10337
Straps: 339035 (takes 2)
J-Bolts: 347014
6" Screw on Cap: 343047



Top Mount Hose Hanger

30 Gallon Snyder Tank
Part #: 109137
Straps: 339035 (takes 2)
J-Bolts: 347014
6" Screw on Cap: 343047



Strainer/Ball Valve Assy

50 Gallon Snyder Tank
Part #: 117137
Straps: 339039 (takes 2)
J-Bolts: 347014
6" Screw on Cap: 343047

Top Mount Hose Hanger



Strainer/Ball Valve Assy

Manifold Breakdown

Manual Boom Control Valve

100 PSI Pressure Gauge
Part #: SG100

3/4 Nipple
Part #: TN 51212

3/4 X 3/8 Straight Barb
Part #: TA 10126

3/4 X 3/4 Elbow
Part: TE 201212
Connects to pressure side of pump with 3/4 red hose.
Hose: UL075

3/4 Threaded Tee
Part: TT 12

Manual Boom Control
Blue Handle: 48120
Grey Handle: AA6B

3/4 X 1/2 Straight Barb (in regulator)
Part #: TA 10128
Connects to return at bottom of tank.

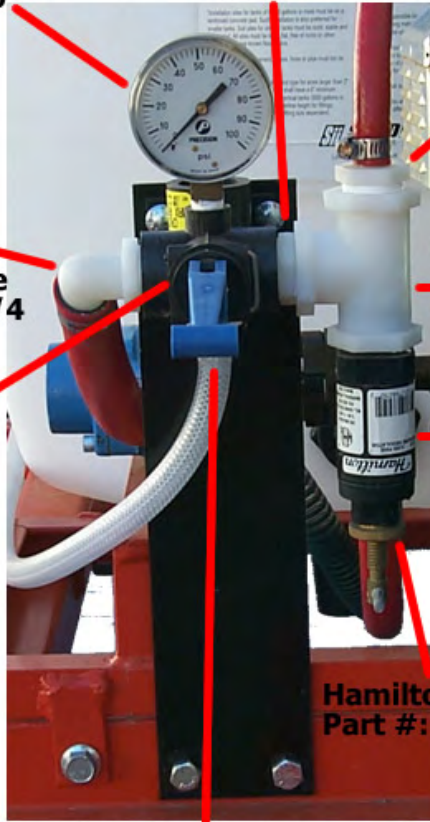

Hamilton Pressure Regulator
Part #: 13895-2

1/2 X 1/2 Straight Barb
Part #: TA 1088
Connects to boom or boomless assy.

Bottom Plumbing/Strainer Assembly

3/4 Street Elbow
Part #: SE 1212

3/4 Bulkhead Fitting
Part #: TF075
Prior to 2006:
Use 1" Bulkhead Fitting
Part #: TF100 with
1 X 3/4 Reducer Bushing
Part #: RB 1612

3/4 Nipple
Part #: TN51212

3/4 Ball Valve
Part #: 201-304

3/4 X 1/2 Straight Barb
Part #: TA 10128



1/2 Red Hose
Part #: UL050
Clamp: #5MINI

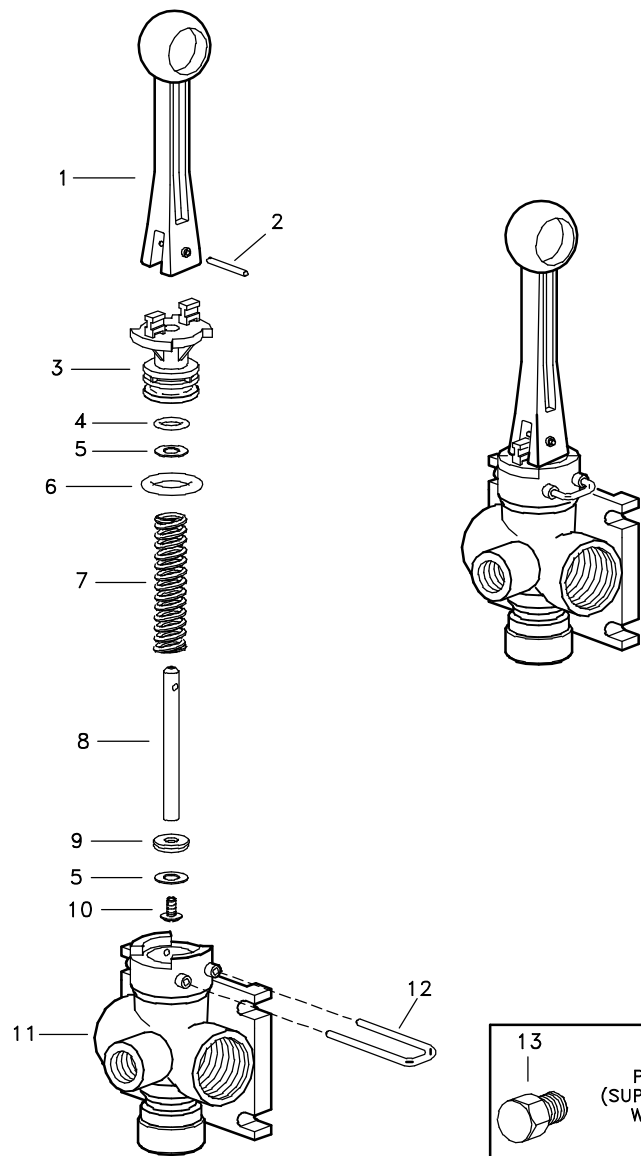

ITEM	PART NO.	DESCRIPTION	
1	CP36301-NY	HANDLE, NYLON (GRAY)	
2	CP36308-SS	GROOVE PIN, TYPE 303 STAINLESS STEEL	
3	CP36302-PP	BODY INSERT, POLYPROPYLENE (BLACK)	
*	4	CP7717-2/108-VI	O-RING, VITON
5	CP36307-PPB	WASHER, POLYPROPYLENE (BLACK) 2 REQ'D	
*	6	CP7717-2/209-VI	O-RING, VITON
7	CP36306-302SS	SPRING, TYPE 302 STAINLESS STEEL	
8	CP36304-SS	STEM, TYPE 303 STAINLESS STEEL	
*	9	CP38726-VI	SHUT-OFF WASHER, VITON
10	CP38725-SS	PHILLIPS HEAD SCREW, TYPE 302 STAINLESS STEEL	
11	CP36303-PP	BODY (NPT), POLYPROPYLENE (BLACK) (FOR MODEL AA6B)	
	CPB36303-PP	BODY (BSPT), POLYPROPYLENE (BLACK) (FOR MODEL AAB6B)	
12	CP36309-302SS	RETAINING CLIP, TYPE 302 STAINLESS STEEL	
13	8400-1/4-PPB	PIPE PLUG (NPT), POLYPROPYLENE (BLACK) (FOR MODEL AA6B)	
	B8400-1/4-PPB	PIPE PLUG (BSPT), POLYPROPYLENE (BLACK) (FOR MODEL AAB6B)	

No. AA6B DIRECTOVALVE MANUAL CONTROL VALVE (NPT THREADS)

No. AAB6B DIRECTOVALVE MANUAL CONTROL VALVE (BSPT THREADS)

PK-AB6B-KIT SPARE PARTS KIT (INCLUDES ALL ITEMS MARKED WITH *)

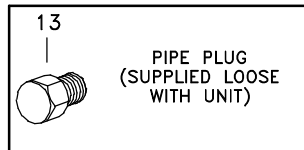

DESCRIPTION:
AA(B)6B
DIRECTOVALVE*
MANUAL CONTROL VALVE
(NPT & BSPT VERSIONS)



Spraying Systems Co.

Spray Nozzles and Accessories
P.O. Box 7900 - Wheaton, IL 60189-7900

Rev. No. 1

Ref.

Parts List No.

PL 6B

SHEET OF

For 6 Roller:
 3/4 Strainer
 Part #: 3440LSB
 For 8 Roller
 Part #: 1040LSB
 For Both:
 Screen: 34104M
 Bowl: 3410BOB
 Gasket: 3410EPDM

For 6 Roller:
 3/4 Nipple
 Part #: TN 51212
 For 8 Roller:
 1' Nipple
 Part #: TN 51616

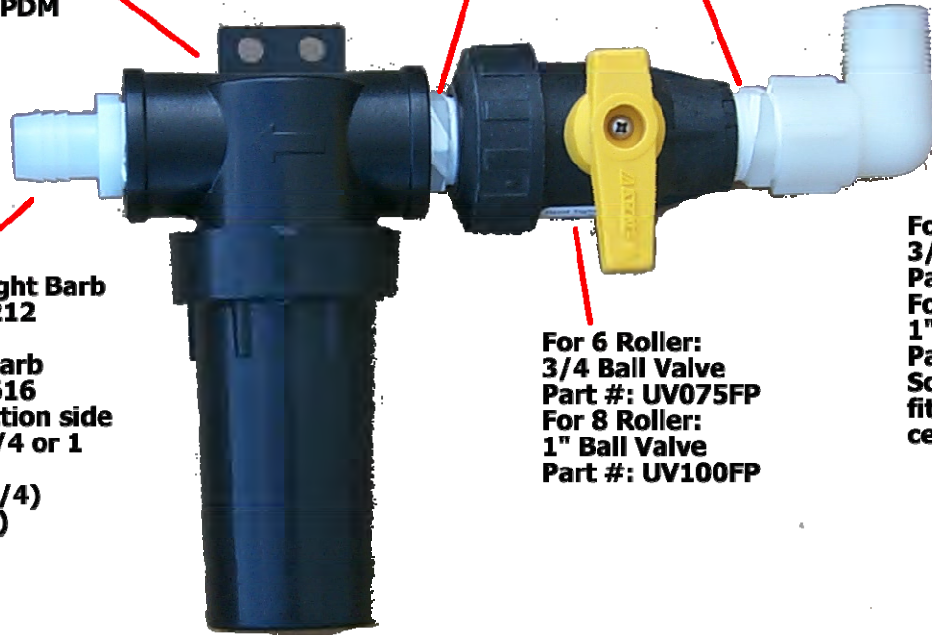

For 6 Roller:
 3/4 X 3/4 Straight Barb
 Part #: TA 101212
 For 8 Roller:
 1 X 1 Straight Barb
 Part #: TA 101616
 Connects to suction side
 of pump with 3/4 or 1
 suction hose.
 Hose: SU075 (3/4)
 Hose: SU100 (1)

For 6 Roller:
 3/4 Ball Valve
 Part #: UV075FP
 For 8 Roller:
 1" Ball Valve
 Part #: UV100FP

For 6 Roller:
 3/4 Street Elbow
 Part #: SE 1212
 For 8 Roller:
 1" Street Elbow
 Part #: SE 1616
 Screws into suction
 fitting in bottom
 center of tank.

Pump Breakdown

Flojet 1.5 GPM Pump
 Part #: 2131F1311

3/8 X 1/2 Elbow
 Part #: TE 2068

1/2 Threaded Tee
 Part #: TT 8

1/2 Nipple
 Part #: TN 5088

1/2 Ball Valve
 Part #: 201-303

1/2 X 1/2 Elbow
 Part #: TE 2088

3/8 Red Hose
 Part #: UL038
 Clamps: #4MINI

1/2 X 3/8 Reducer Nipple
 Part #: TRN 6086

1/2 X 3/8 Straight Barb
 Part #: TA 1086

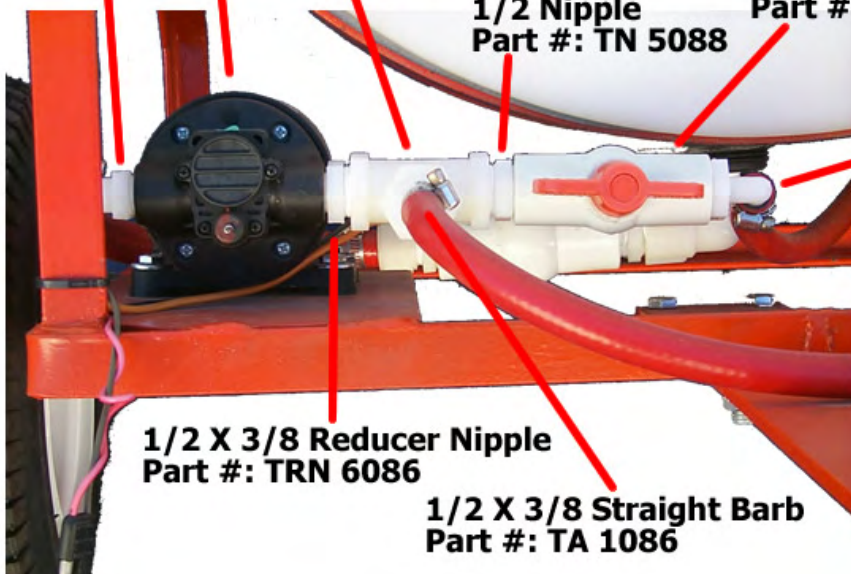

LovJoy on Pump side:
Part #: LOVJOY95-5/8
Spider: SPIDER
LovJoy on Engine side:
Part #: LOVJOY95-3/4

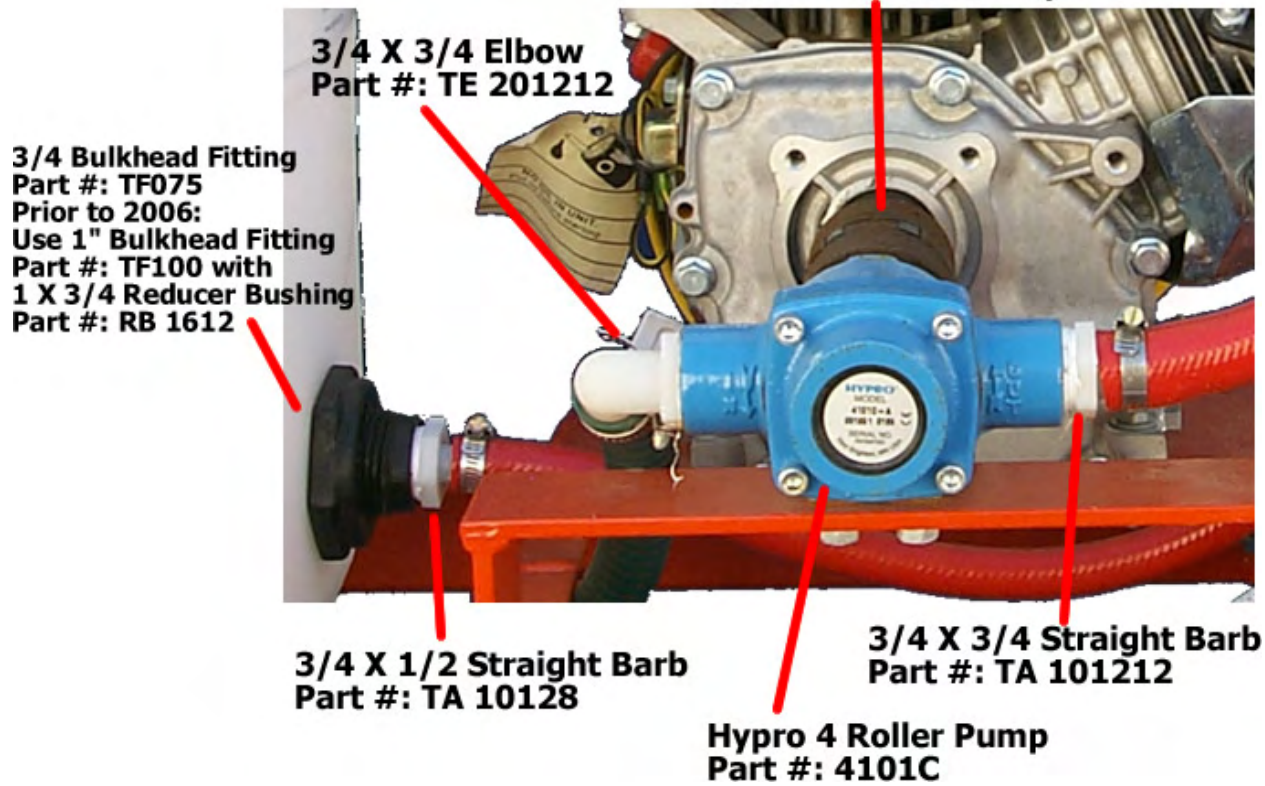

Bottom Fitting Assembly

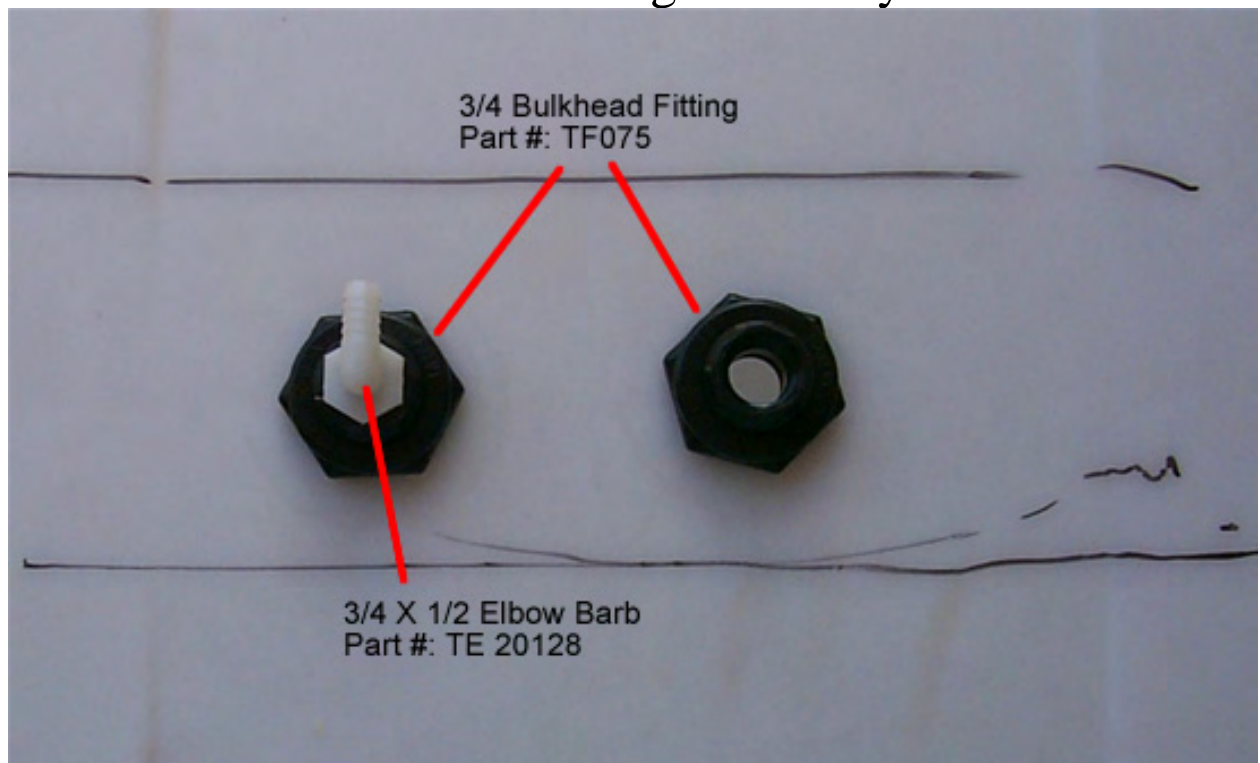

Handgun Breakdown

3/8 Red Hose (Per Foot)
Part #: UL038



3/4 X 3/8 Straight Barb
Part #: TA 10126



1/2 X 3/8 Straight Barb
Part #: TA 1086

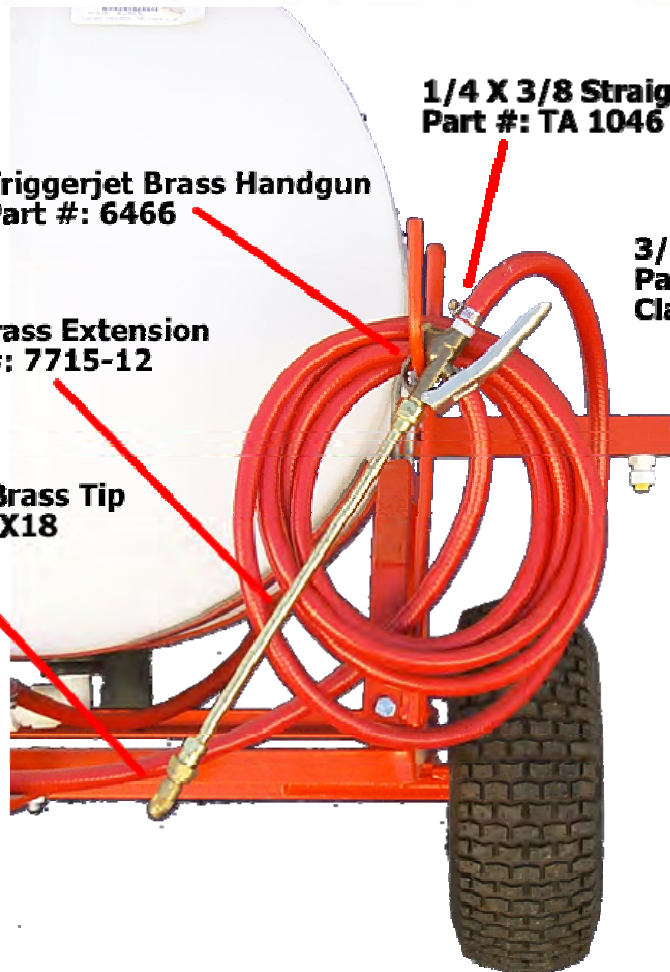

1/4 X 3/8 Straight Barb
Part #: TA 1046

Triggerjet Brass Handgun
Part #: 6466

3/8 Red Hose
Part #: UL038
Clamp: #4MINI

12" Brass Extension
Part #: 7715-12

Adj. Conejet Brass Tip
Part #: 5500-X18

Repair kit for 6466
Part #: AB6466-KIT

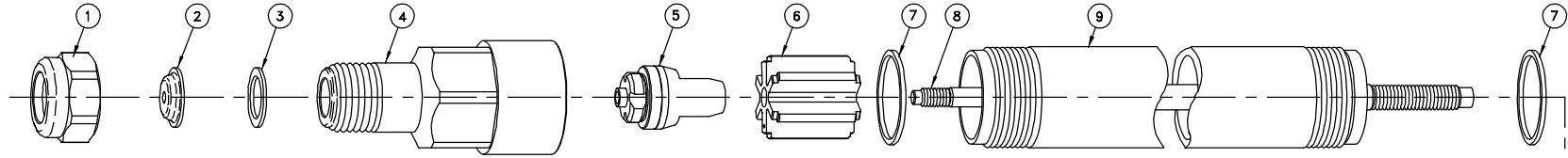

ITEM NO.	PART NO.	DESCRIPTION	
1	CP1325-AL	Cap, Aluminum	
2	D_	Orifice Disc, Hardened Stainless Steel (Specify Size)	
*	CP4743-NY	Gasket, Nylon	
4	CP10566-AL	Nozzle Housing, Aluminum	
*	5	10565-1-NY-AL	Seat Plug, Seat Plate, Washer & Core Sub-Assembly Nylon Core, Viton Plate with Aluminum Seat Plug
6	CP10571-3-NYB	Guide Vane, Nylon (Black)	
7	CP45196-NYB	Gasket, Nylon (Black) (2 Required)	
8	CP10576-416SS	Stem, Type 416 Stainless Steel	
9	CP6604-AL	Tubing, Aluminum	
10	CP6618-AL	Nut, Aluminum	
11	CP6898-GH-AL	Inlet Body, Garden Hose (Female) Thread, Aluminum (For AA143-AL-GH)	
	CP6898-3/4-AL	Inlet Body, 3/4" NPT (Female) Thread, Aluminum (For AA143-AL-3/4)	
12	CP5882-NP	Hand Grip Stud, Brass-Nickel Plated	
13	CP5883-AL	Packing Washer, Aluminum	
*	14	CP5809-LEA	Packing, Thermo-Leather (4 Required)
15	CP5811-AL	Packing Screw, Aluminum	
16	CP5884-INP	Hand Grip Collar, Steel-Nickel Plated	
17	CP5994-2-NY	Hand Grip, Nylon	
18	CP5813-AL	Hand Grip Nut, Aluminum	
19	CP5808-POL	Garden Hose Gasket, Polyethylene	
PK-AB143-AL-KIT Spare Parts Kit (Includes items marked with *)			
No. AA143-AL-GH-__ GunJet® Spray Gun, Aluminum (Specify Orifice Size in Part Number)			
No. AA143-AL-3/4-6 GunJet® Spray Gun, Aluminum			

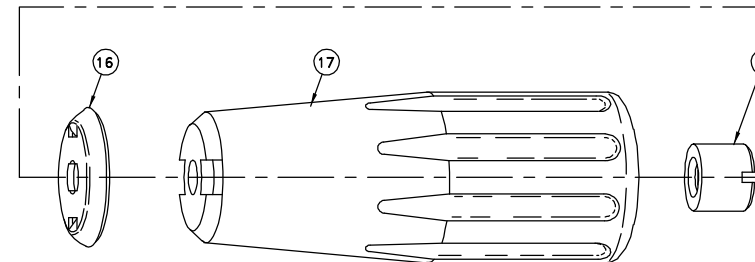
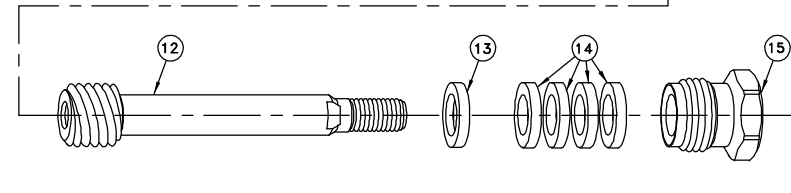
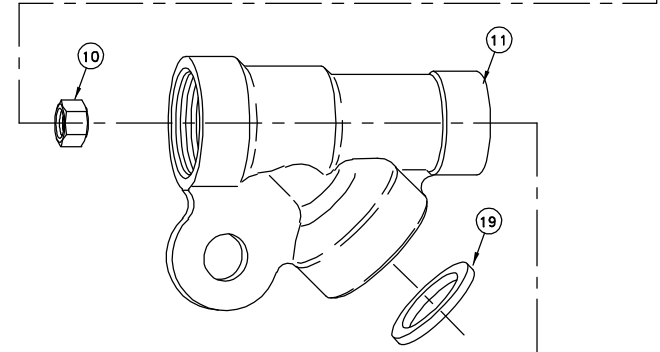

DESCRIPTION:
AA143-AL
ALUMINUM TWIST-HANDLE
GUNJET® SPRAY GUN



Spraying Systems Co.®
Spray Nozzles and Accessories
P.O. Box 7900 - Wheaton, IL 60189-7900

Rev. No. 1

Parts List No.

Ref.

PL 143
SHEET OF

ITEM	PART NO.		DESCRIPTION
	BRASS	ALUMINUM	
1	CP1325	CP1325-AL	Cap, Brass or Aluminum
2	D-**	D-**	Orifice Disc, Hardened Stainless Steel
* 3	CP4743-NY	CP4743-NY	Gasket, Nylon
* 4	CP10566	CP10566-AL	Nozzle Housing, Brass or Aluminum
5	10565-1-NY	10565-1-NY-AL	Seat Plug, Seat Plate, Washer & Core Sub-Assembly Nylon Core With Brass Or Aluminum Seat Plug
5A	10565	10565-AL	Seat Plug, Seat Plate, Washer & Core Sub-Assembly Brass Or Aluminum (SPECIAL ORDER ONLY)
6	CP10571-2-NYB	CP10571-3-NYB	Guide Vane, Nylon
6A		CP10571-AL	Guide Vane, Aluminum (SPECIAL ORDER ONLY)
7	CP45195-NYB	CP45196-NYB	Gasket, Nylon (Black) 2 Req'd
8	CP19238-416SS	CP19238-416SS	Stem, Type 416 Stainless Steel
9	CP6604	CP6604-AL	Tubing, Brass or Aluminum
10	CP6492	CP6492-AL	Inlet Body, Brass or Aluminum
* 11	CP6601-302SS	CP6601-302SS	Packing Washer, Type 302 Stainless Steel
* 12	CP6602-LEA	CP6602-LEA	Packing, Leather (3 Req'd), Standard
	CP6602-TEF	CP6602-TEF	Packing, Teflon (3 Req'd), Optional
13	CP19237	CP19237-AL	Packing Screw, Brass or Aluminum
14	CP6599-NP	CP6599-NP	Locknut, Brass, Nickel Plated
15	CP9641-INP	CP9641-INP	Stem Nut, Steel, Nickel Plated
16	CP6595-SS	CP6595-SS	Trigger Stop Spring, Stainless Steel
17	CP7991-SS	CP7991-SS	Washer, Stainless Steel
18	CP6597-INP	CP6597-INP	Trigger Guide, Steel, Nickel Plated
19	CP6591-SS	CP6591-SS	Spring Stud, Stainless Steel
20	CP6589-IZP	CP6589-IZP	Stop Adjustment Nut, Steel, Zinc Plated
21	CP6594-SS	CP6594-SS	Spring for Stop Adjustment Nut, Stainless Steel
22	CP6588-IZP	CP6588-IZP	Spring Screw, Steel, Zinc Plated
23	CP6592-302SS	CP6592-302SS	Spring Guide Washer, Type 302 Stainless Steel
24	CP6593-1-SS	CP6593-1-SS	Main Spring, Stainless Steel (for Model #43L-)
	CP6593-2-SS	CP6593-2-SS	Main Spring, Stainless Steel (for Model #43H-)
25	CP14477-1-AL	CP14477-1-AL	GunJet Body, Aluminum
26	CP7623-IZP	CP7623-IZP	Rivet, Steel, Zinc Plated (2 Req'd)
27	CP6509-INP	CP6509-INP	Trigger, Steel, Nickel Plated
28	CP6510-INP	CP6510-INP	Trigger Stop, Steel, Nickel Plated
29	CP11757-SS	CP11757-SS	Screw, Stainless Steel
30	CP13798-INP	CP13798-INP	Trigger Guard, Steel, Nickel Plated

GunJet® No. AA43L - Brass, Complete, For Pressures up to 200 PSI
 GunJet® No. AA43L-AL - Aluminum, Complete, For Pressures up to 200 PSI
 GunJet® No. AA43H - Brass, Complete, For Pressures from 200 to 800 PSI
 GunJet® No. AA43H-AL - Aluminum, Complete, For Pressures from 200 to 800 PSI
 PK-AB43-KIT Spare parts Kit (Includes all items marked with *)
 PK-AB43-AL-KIT Spare parts Kit (Includes all items marked with *)
 ABCK43-KIT Conversion Kit for Adjustable Stem - Items 8, 13 & 15 (for Model #43--)
 ABCK43-AL-KIT Conversion Kit for Adjustable Stem - Items 8, 13 & 15 (for Model #43-AL--)

** Specify Orifice Disc Size

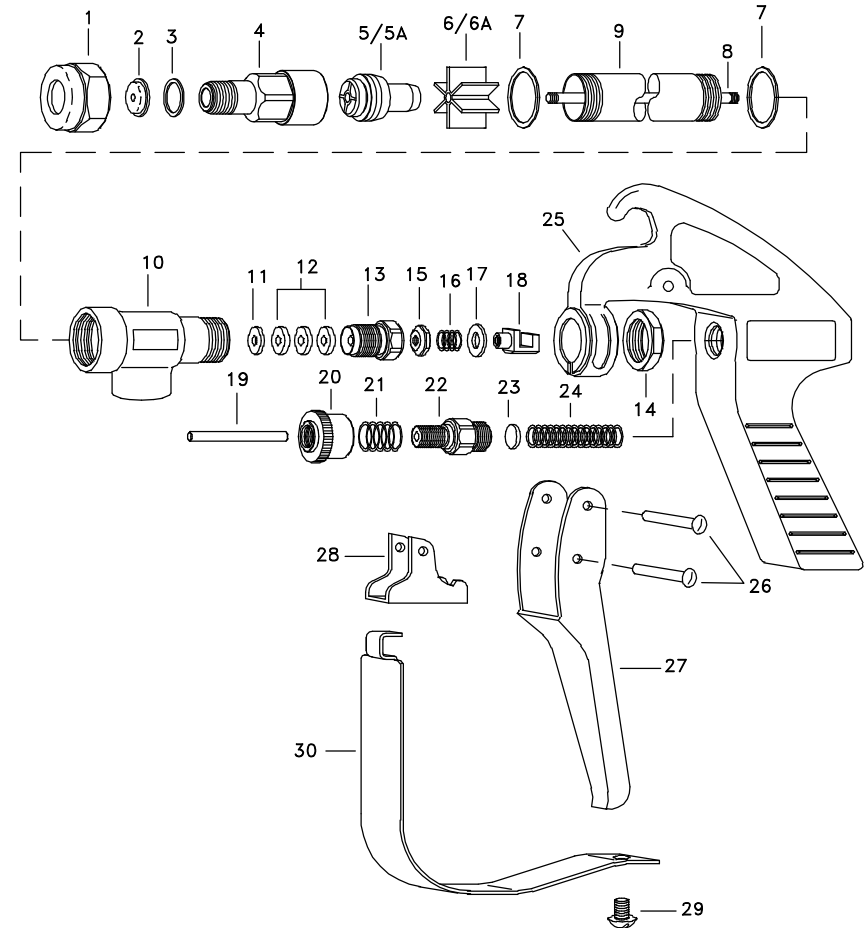

DESCRIPTION:
 AA43L & 43H
 GUNJET® SPRAY GUNS
 (13 INCH EXTENSION)



Spraying Systems Co.®
 Spray Nozzles and Accessories
 P.O. Box 7900 - Wheaton, IL 60189-7900

Rev. No.

Parts List No.

Ref.

PL 43
 SHEET OF

Boom Breakdowns

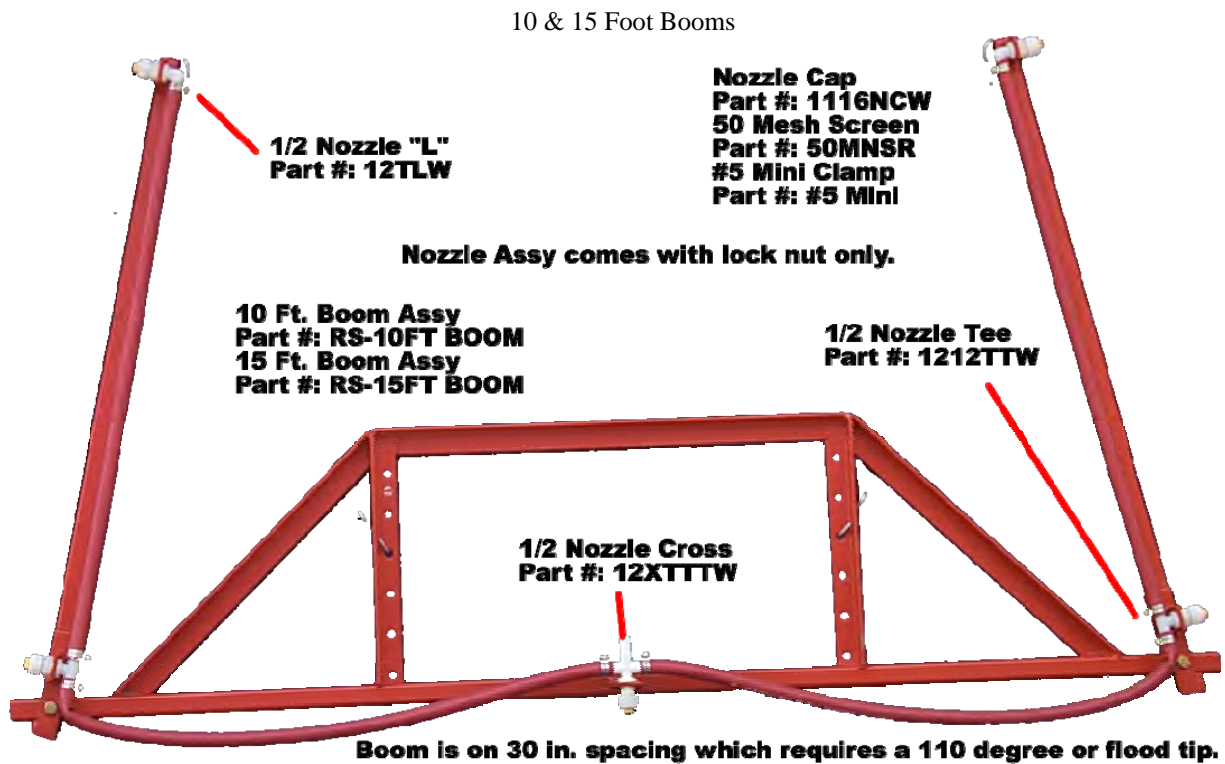
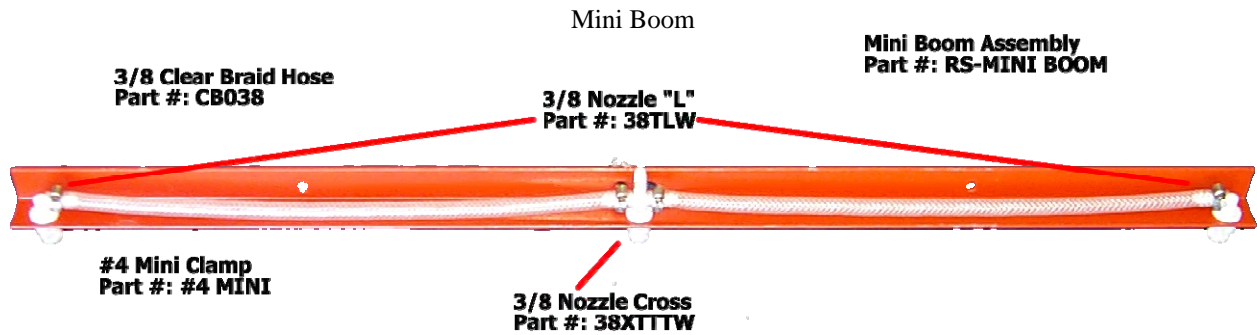

17, 20 & 23 Foot Booms

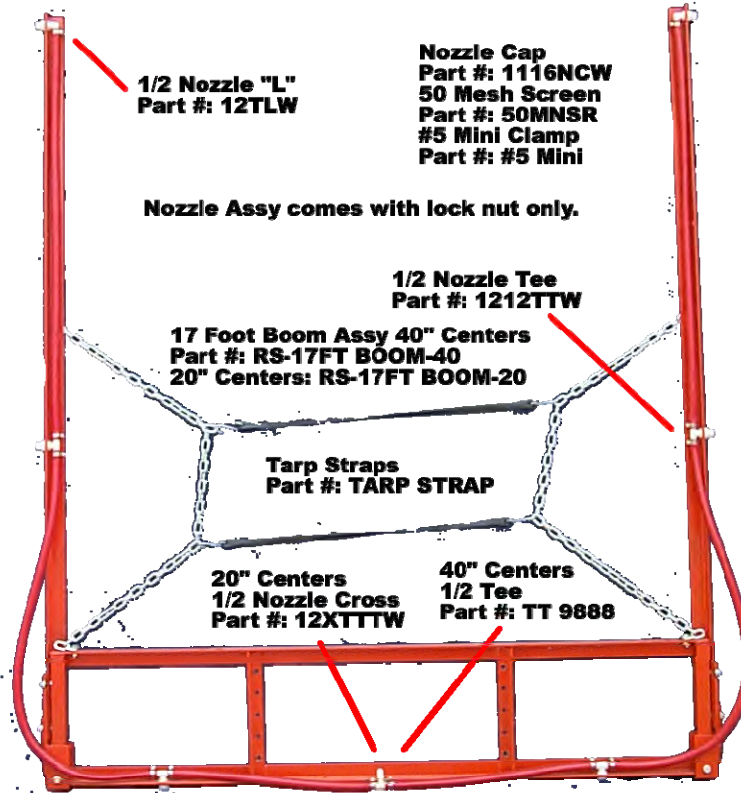

18 Foot Turf Boom

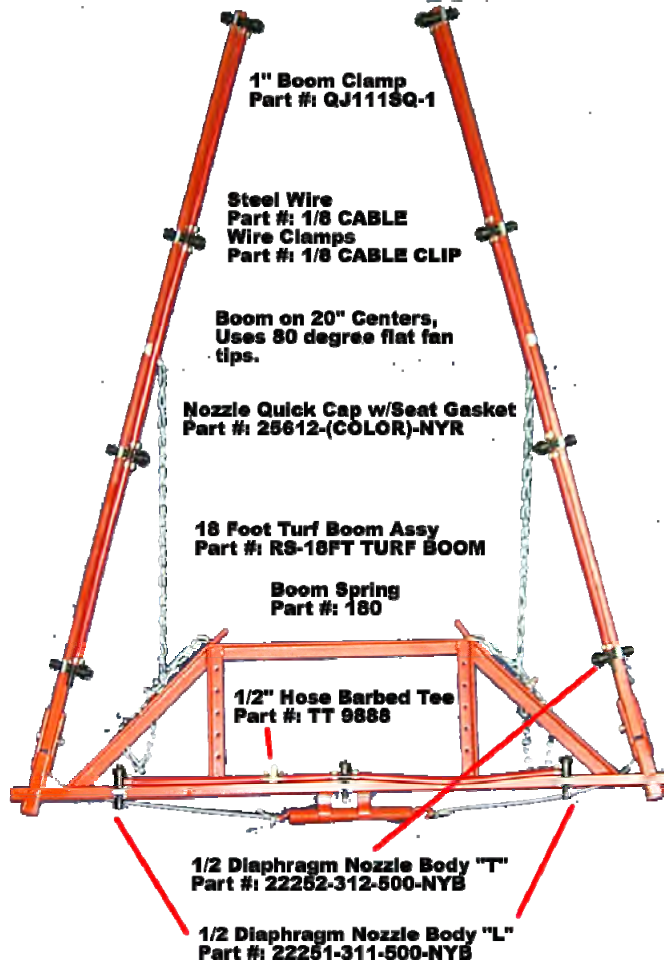

For Demco boom Breakdowns, Please consult the package that came with your sprayer or visit: www.demco-products.com

Pasture Nozzle



Pasture Nozzle
Part #: 6541-01
#20 Pasture Nozzle
Part #: 6542-01

Pasture Nozzle Assy
Part #: PASTURE NOZ ASSY-#10
#20 Pasture Nozzle Assy
Part#: PASTURE NOZ ASSY-#20

Pasture Nozzle Application Chart

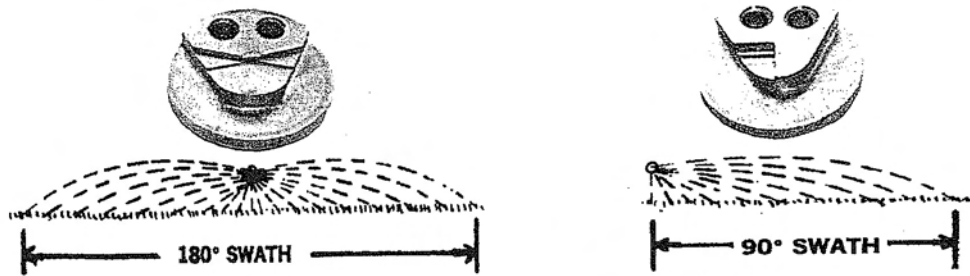

OPERATING DATA FOR 180° NOZZLES								
Orifice No.	PSI	GPM 180°	SWATH 180°	GALLONS PER ACRE				
				3 MPH	4 MPH	5 MPH	8 MPH	10 MPH
# 5	30	1.7	44'	6.4	4.8	3.8	2.4	1.9
	40	2.0	46'	7.2	5.4	4.3	2.7	2.2
	50	2.2	48'	7.6	5.7	4.5	2.9	2.3
	60	2.4	50'	7.9	5.9	4.8	3.0	2.4
# 10	30	3.7	50'	12.2	9.2	7.3	4.6	3.7
	40	4.2	50'	13.9	10.4	8.3	5.2	4.2
	50	4.6	52'	14.6	10.9	8.8	5.5	4.4
	60	5.0	52'	15.8	11.9	9.5	5.9	4.8
# 20	30	5.1	54'	15.6	11.6	9.3	5.8	4.7
	40	5.9	54'	18.0	13.5	10.8	6.8	5.4
	50	6.7	56'	19.7	14.8	11.8	7.4	5.9
	60	7.1	58'	20.2	15.1	12.1	7.6	6.1

NOTE: 90° nozzles have the same GPA but 1/2 GPM and swath

Cluster Nozzle

Cluster Nozzle Assy
Part #: 5880 ASSY-#10
#20 Cluster Nozzle Assy
Part #: 5880 ASSY-#20



Cluster Nozzle
Part #: 5880-3/4-2TOC10
#20 Cluster Nozzle
Part #: 5880-3/4-2TOC20

3/4 X 3/4 Straight Barb
Part #: TA101212

Cluster Nozzle Application Chart

Cluster Nozzle Assy	Nozzle (2)	Nozzle (2)	Nozzle (1)	PSI	GPM	"W" (FEET)	GPA					GALLONS PER 1000 SQ. FT.			
							4 MPH	5 MPH	7.5 MPH	10 MPH	15 MPH	2 MPH	3 MPH	4 MPH	5 MPH
5880-3/4-2TOC06	6733-OC06	H1/4VV-1506	H1/4VVL-9502 with 50 mesh strainer	20	1.84	33.5	6.8	5.4	3.6	2.7	1.8	0.31	0.21	0.16	0.12
				30	2.25	34	8.2	6.6	4.4	3.3	2.2	0.38	0.25	0.19	0.15
				40	2.60	34.5	9.3	7.5	5.0	3.7	2.5	0.43	0.28	0.21	0.17
5880-3/4-2TOC10	OC10	H1/4U-0508HE	H1/4VVL-11004 with 50 mesh strainer	20	2.83	39.5	8.9	7.1	4.7	3.5	2.4	0.41	0.27	0.20	0.16
				30	3.46	40	10.7	8.6	5.7	4.3	2.9	0.49	0.33	0.25	0.20
				40	4.00	40.5	12.2	9.8	6.5	4.9	3.3	0.56	0.37	0.28	0.22
5880-3/4-2TOC20	OC20	H1/4U-0520HE	H1/4VVL-9506 with 50 mesh strainer	20	6.08	47	16.0	12.8	8.5	6.4	4.3	0.73	0.49	0.37	0.29
				30	7.45	50	18.4	14.8	9.8	7.4	4.9	0.84	0.56	0.42	0.34
				40	8.60	52	20	16.4	10.9	8.2	5.5	0.94	0.62	0.47	0.37
5880-3/4-2TOC40	OC40	H1/4U-0540HE	H1/4U-9510	20	12.0	56	27	21	14.1	10.6	7.1	1.2	0.81	0.61	0.49
				30	14.7	60	30	24	16.2	12.1	8.1	1.4	0.93	0.69	0.56
				40	17.0	63	33	27	17.8	13.4	8.9	1.5	1.0	0.76	0.61

Note: Always double check your application rates. See pages 153-157 for useful formulas and information.

XP Tips

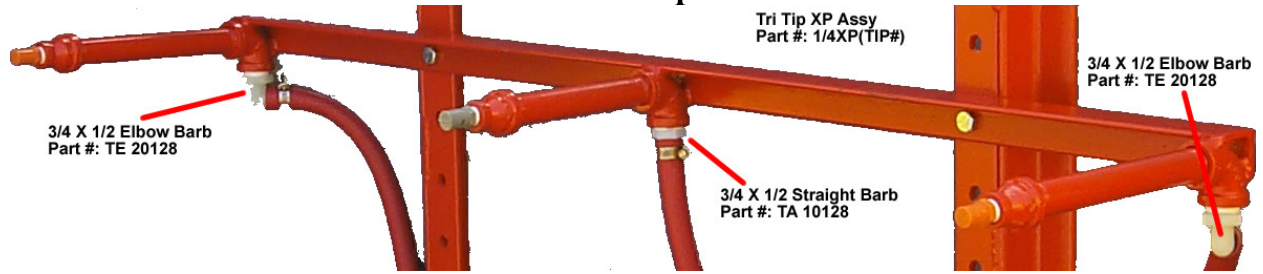

Orange : 1/4XP10(L)(R)-VP (L or r for Left and right)

Yellow : 1/4XP20(l)(r)-VP

Violet : 1/4XP25(l)(r)-VP

Red : 1/2XP40(l)(r)-VP

White : 1/2XP80(l)(r)-VP

XP BoomJet[®] BOOMLESS FLAT SPRAY NOZZLE WITH **VisiFlo[®]** COLOR CODING

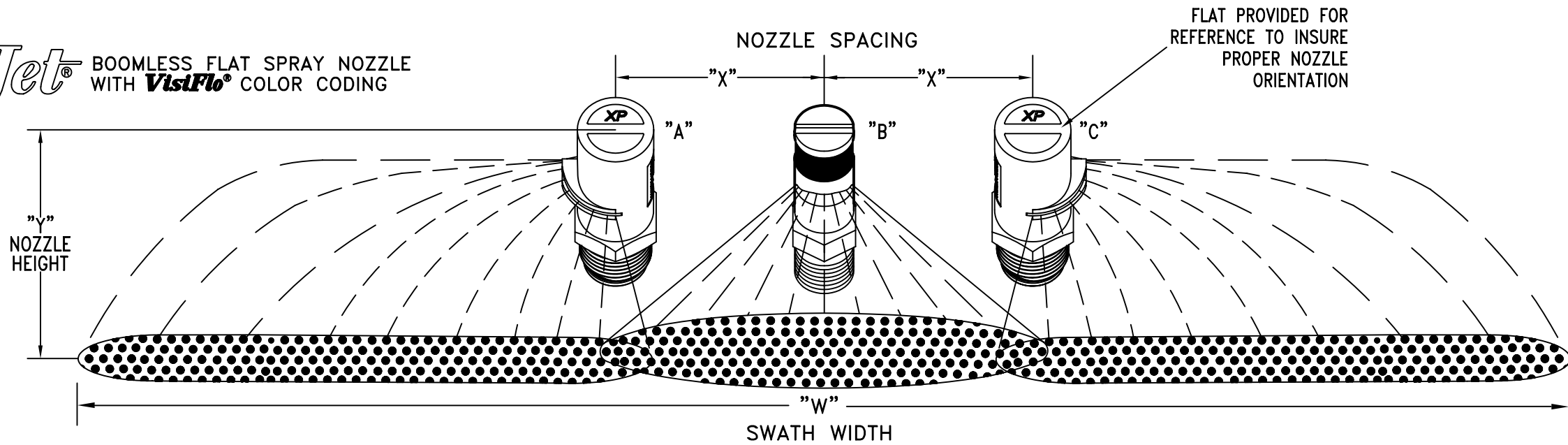

Outer Nozzle "A"	Outer Nozzle "C"	Liquid Pressure (psi)	Center Nozzle "B"	Capacity 3 Nozzles (GPM)	Nozzle Spacing "X" = 20"										Nozzle Spacing "X" = 30"											
					Swath Width "W" (ft)		Gallons Per Acre (Three Nozzles)								Center Nozzle "B"	Capacity 3 Nozzles (GPM)	Swath Width "W" (ft)		Gallons Per Acre (Three Nozzles)							
					24" Height	36" Height	Height "Y" = 24"				Height "Y" = 36"						24" Height	36" Height	Height "Y" = 24"				Height "Y" = 36"			
							2 mph	4 mph	6 mph	10 mph	2 mph	4 mph	6 mph	10 mph					2 mph	4 mph	6 mph	10 mph	2 mph	4 mph	6 mph	10 mph
(B)1/4XP10L-VP (B)1/4XP10R-VP	(B)1/4XP10L-VP (B)1/4XP10R-VP	20 30 40 50 60	1/4TTJ08	2.43 2.80 3.13 3.42	23.3 25.3 28.3 29.3	25.3 28.3 30.3 32.3	26 27 27 29	12.9 13.7 13.7 14.4	8.6 9.1 9.1 9.6	5.2 5.5 5.5 5.8	24 24 26 26	11.9 12.2 12.8 13.1	7.9 8.2 8.5 8.7	4.7 4.9 5.1 5.2	1/4TTJ06	2.26 2.60 2.91 3.17	25.0 27.0 30.0 31.0	27.0 30.0 32.0 34.0	22 24 24 25	11.2 11.9 12.0 12.7	7.5 7.9 8.0 8.4	4.5 4.8 4.8 5.1	21 21 23 23	10.4 10.7 11.3 11.5	6.9 7.2 7.5 7.7	4.1 4.3 4.5 4.6
(B)1/4XP20L-VP (B)1/4XP20L-VS	(B)1/4XP20R-VP (B)1/4XP20R-VS	20 30 40 50 60	1/4TTJ08	4.19 4.80 5.39 5.98	26.3 30.3 32.3 33.3	27.3 31.3 33.3 35.3	39 39 41 44	19.7 19.6 21 22	13.1 13.1 13.8 14.8	7.9 7.8 8.3 8.9	38 38 40 42	19.0 19.0 20 21	12.6 12.6 13.3 14.0	7.6 7.6 8.0 8.4	1/4TTJ06	4.02 4.60 5.17 5.73	28.0 32.0 34.0 35.0	29.0 33.0 35.0 37.0	36 36 38 41	17.8 17.8 18.8 20	11.8 11.9 12.5 13.5	7.1 7.1 7.5 8.1	34 35 37 38	17.2 17.3 18.3 19.2	11.4 11.5 12.2 12.8	6.9 6.9 7.3 7.7
(B)1/4XP25L-VP (B)1/4XP25L-VS	(B)1/4XP25R-VP (B)1/4XP25R-VS	20 30 40 50 60	1/4TTJ10	5.13 6.00 6.62 7.22	27.3 30.3 32.3 33.3	30.3 32.3 33.3 35.3	46 49 51 54	23 24 25 27	15.5 16.3 16.9 17.9	9.3 9.8 10.1 10.7	42 46 49 51	21 23 25 25	14.0 15.3 16.4 16.9	8.4 9.2 9.8 10.1	1/4TTJ08	4.95 5.80 6.39 6.98	29.0 32.0 34.0 35.0	32.0 34.0 35.0 37.0	42 45 47 49	21 22 23 25	14.1 15.0 15.5 16.5	8.4 9.0 9.3 9.9	38 42 45 47	19.1 21 23 23	12.8 14.1 15.1 15.6	7.7 8.4 9.0 9.3
(B)1/2XP40L-VP (B)1/2XP40L-VS	(B)1/2XP40R-VP (B)1/2XP40R-VS	20 30 40 50 60	1/4TTJ15	8.36 9.50 10.8 11.8	29.3 31.3 33.3 35.3	32.3 34.3 35.3 38.3	71 75 80 83	35 38 40 41	24 25 27 28	14.1 15.0 16.0 16.5	64 68 76 76	32 34 38 38	21 23 25 25	12.8 13.7 15.1 15.2	1/4TTJ10	7.93 9.00 10.2 11.2	31.0 33.0 35.0 37.0	34.0 36.0 37.0 40.0	63 68 72 75	32 34 36 37	21 23 24 25	12.7 13.5 14.4 15.0	58 62 68 69	29 31 34 35	19.2 21 23 23	11.5 12.4 13.6 13.9
(B)1/2XP80L-VP (B)1/2XP80L-VS	(B)1/2XP80R-VP (B)1/2XP80R-VS	20 30 40 50 60	--	-- -- -- --	-- -- -- --	-- -- -- --	-- -- -- --	-- -- -- --	-- -- -- --	-- -- -- --	-- -- -- --	-- -- -- --	-- -- -- --	-- -- -- --	1/4TTJ15	15.0 17.5 19.1 21.0	35.0 37.0 38.0 40.0	38.0 40.0 41.0 42.0	106 117 124 130	53 59 62 65	35 39 41 43	21 23 25 26	98 108 115 124	49 54 58 62	33 36 38 41	19.5 22 23 25

TABULATION BASED ON SPRAYING WATER AT 70° F WITH NOZZLE POSITIONED PARALLEL TO GROUND AND FLAT ON END OF NOZZLE IN HORIZONTAL POSITION.
NOTE: (B) IN PART NUMBER SPECIFIES BSPT THREAD.

DESCRIPTION:
APPLICATION DATA FOR
XP BOOMJET
BOOMLESS SPRAY NOZZLE
IN A THREE NOZZLE
CONFIGURATION



Spraying Systems Co.[®]

Spray Nozzles and Accessories
P.O. Box 7900 - Wheaton, IL 60189-7900

Rev. No.

Ref.

DATA SHEET

55200-2

SHEET OF

Technical Information

Useful Formulas

$$\text{GPM (Per Nozzle)} = \frac{\text{GPA} \times \text{MPH} \times \text{W}}{5,940}$$

$$\text{GPM (Per Nozzle)} = \frac{\text{GAL}/1000\text{FT}^2 \times \text{MPH} \times \text{W}}{136}$$

$$\text{GPA} = \frac{5,940 \times \text{GPM (Per Nozzle)}}{\text{MPH} \times \text{W}}$$

$$\text{GAL}/1000\text{FT}^2 = \frac{136 \times \text{GPM (Per Nozzle)}}{\text{MPH} \times \text{W}}$$

GPM – Gallons Per Minute

GPA – Gallons Per Acre

GAL/1000FT² – Gallons Per 1000 Square Feet

MPH – Miles Per Hour

W – Nozzle spacing (in inches) for broadcast spraying

– Spray width (in inches) for single nozzle, band spraying or boomless spraying

– Row spacing (in inches) divided by the number of nozzles per row for directed spraying

Nozzle Spacing

If the nozzle spacing on your boom is different than those tabulated, multiply the tabulated GPA coverages by one of the following factors.

20"	
Other Spacing (inches)	Conversion Factor
8	2.5
10	2
12	1.67
14	1.43
16	1.25
18	1.11
22	.91
24	.83
30	.66

30"	
Other Spacing (inches)	Conversion Factor
26	1.15
28	1.07
32	.94
34	.88
36	.83
38	.79
40	.75
42	.71
44	.68

40"	
Other Spacing (inches)	Conversion Factor
28	1.43
30	1.33
32	1.25
34	1.18
36	1.11
38	1.05
42	.95
44	.91
48	.83

Miscellaneous Conversion Factors

One Acre = 43,560 square feet
= 43.56 1000 FT² blocks
= 0.405 Hectares

One Hectare = 2.471 Acres

One Gallon Per Acre
= 2.9 Fluid Ounces per 1000FT²
= 9.35 Liters Per Hectare

One Gallon Per 1000FT² = 43.56 GPA

One Mile = 5,280 Feet
= 1,610 Meters
= 1.61 Kilometers

One Gallon = 128 Fluid Ounces
= 8 Pints
= 4 Quarts
= 3.79 Liters
= 0.83 Imperial Gallons

One Pound Per Square Inch
= 0.069 bar
= 6.896 Kilopascal

One Mile Per Hour = 1.609 Kilometers Per Hour

Measuring Travel Speed

Measure a test course in the area to be sprayed or in an area with similar surface conditions. Minimum lengths of 100 and 200 feet are recommended for measuring speeds up to 5 and 10 mph, respectively. Determine the time required to travel the test course. To help ensure accuracy, conduct the speed check with a partially loaded (about half full) sprayer and select the engine throttle setting and gear that will be used when spraying. Repeat the above process and average the times that were measured. Use the following equation or the table below to determine ground speed.



$$\text{Speed (MPH)} = \frac{\text{Distance (ft)} \times 60}{\text{Time (seconds)} \times 88}$$

Speeds

Speed in MPH	Time Required in SECONDS to Travel a Distance of:		
	100 Feet	200 Feet	300 Feet
1.0	68	136	205
1.5	45	91	136
2.0	34	68	102
2.5	27	55	82
3.0	23	45	68
3.5	19	39	58
4.0	17	34	51
4.5	15	30	45
5.0	14	27	41
5.5	—	25	37
6.0	—	23	34
6.5	—	21	31
7.0	—	19	29
7.5	—	18	27
8.0	—	17	26
8.5	—	16	24
9.0	—	15	23

Suggested Minimum Spray Heights

The nozzle height suggestions in the table below are based on the minimum overlap required to obtain uniform distribution. However, in many cases, typical height adjustments are based on a 1 to 1 nozzle spacing to height ratio. For example, 110° flat spray tips spaced 20 inches apart, are commonly set 20 inches above the target.

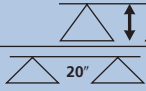
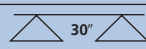
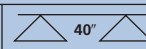
	(Inches)			
				
TeeJet® Standard, TJ	65°	22-24"	33-35"	NR*
TeeJet, XR, TX, DG, TJ	80°	17-19"	26-28"	NR*
TeeJet, XR, DG, TT, TJ, AI	110°	16-18"	20-22"	NR*
FullJet®	120°	10-18"***	14-18"***	14-18"***
FloodJet® TK, TF	120°	14-16"***	15-17"***	18-20"***

* Not recommended.

** Nozzle height based on 30° to 45° angle of orientation (see page 24 of catalog).

*** Wide angle spray tip height is influenced by nozzle orientation. The critical factor is to achieve a double spray pattern overlap.

$$A = \frac{B+C}{D}$$

Technical Information

Spraying Solutions Other Than Water — New Method

Since all the tabulations in this catalog are based on spraying water, which weighs 8.34 lbs. per USA gallon, conversion factors must be used when spraying solutions which are heavier or lighter than water. To determine the proper size nozzle for the solution to be sprayed, first multiply the desired GPM or GPA of solution by the water rate conversion factor. Then use the new converted GPM or GPA rate to select the proper size nozzle.

Example:

Desired application rate is 20 GPA of 28%N. Determine the correct nozzle size as follows:

$$\text{GPA (solution)} \times \text{Conversion factor} = \text{GPA (from table)}$$

$$20 \text{ GPA (28\%)} \times 1.13 = 22.6 \text{ GPA (water)}$$

The applicator should choose a nozzle size that will supply 22.6 GPA of water at the desired pressure.

Weight of Solution	Specific Gravity	Conversion Factors
7.0 lbs./gal.	.84	.92
8.0 lbs./gal.	.96	.98
8.34 lbs./gal.	1.00 – WATER	1.00
9.0 lbs./gal.	1.08	1.04
10.0 lbs./gal.	1.20	1.10
10.65 lbs./gal.	1.28 – 28% nitrogen	1.13
11.0 lbs./gal.	1.32	1.15
12.0 lbs./gal.	1.44	1.20
14.0 lbs./gal.	1.68	1.30

Spray Coverage Information

This table lists the theoretical coverage of spray patterns as calculated from the included spray angle of the spray and the distance from the nozzle orifice. These values are based on the assumption that the spray angle remains the same throughout entire spray distance. In actual practice, the tabulated spray angle does not hold for long spray distances.

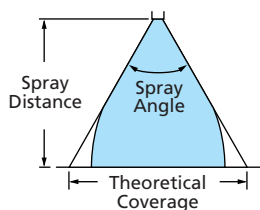

Included Spray Angle	Theoretical Coverage at Various Spray Heights (in inches)							
	8"	10"	12"	15"	18"	24"	30"	36"
15°	2.1	2.6	3.2	3.9	4.7	6.3	7.9	9.5
20°	2.8	3.5	4.2	5.3	6.4	8.5	10.6	12.7
25°	3.5	4.4	5.3	6.6	8.0	10.6	13.3	15.9
30°	4.3	5.4	6.4	8.1	9.7	12.8	16.1	19.3
35°	5.0	6.3	7.6	9.5	11.3	15.5	18.9	22.7
40°	5.8	7.3	8.7	10.9	13.1	17.5	21.8	26.2
45°	6.6	8.3	9.9	12.4	14.9	19.9	24.8	29.8
50°	7.5	9.3	11.2	14.0	16.8	22.4	28.0	33.6
55°	8.3	10.3	12.5	15.6	18.7	25.0	31.2	37.5
60°	9.2	11.5	13.8	17.3	20.6	27.7	34.6	41.6
65°	10.2	12.7	15.3	19.2	22.9	30.5	38.2	45.8
73°	11.8	14.8	17.8	22.0	27.0	36.0	44.0	53.0
80°	13.4	16.8	20.2	25.2	30.3	40.3	50.4	60.4
85°	14.7	18.3	22.0	27.5	33.0	44.0	55.4	66.4
90°	16.0	20.0	24.0	30.0	36.0	48.0	60.0	72.0
95°	17.5	21.8	26.2	32.8	40.3	52.4	65.5	78.6
100°	19.1	23.8	28.6	35.8	43.0	57.2	71.6	85.9
110°	22.8	28.5	34.3	42.8	51.4	68.5	85.6	103
120°	27.7	34.6	41.6	52.0	62.4	83.2	104	
130°	34.3	42.9	51.5	64.4	77.3	103		
140°	43.8	54.8	65.7	82.2	98.6			
150°	59.6	74.5	89.5					

Nozzle Nomenclature

There are many types of nozzles available with each providing different flow rates, spray angles, droplet sizes and patterns. Some of these spray tip characteristics are indicated by the tip number.

Remember, when replacing tips, be sure to purchase the same tip number thereby ensuring your sprayer remains properly calibrated.

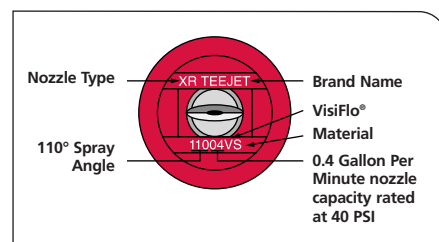

Pressure Information

Flow Rate

Nozzle flow rate varies with spraying pressure. In general, the relationship between GPM and pressure is as follows:

$$\frac{\text{GPM}_1}{\text{GPM}_2} = \frac{\sqrt{\text{PSI}_1}}{\sqrt{\text{PSI}_2}}$$

This equation is explained by the illustration to the right. Simply stated, in order to double the flow through a nozzle, the pressure must be increased four times.

Higher pressure not only increases the flow rate through a nozzle, but it also influences the droplet size and the rate of orifice wear. As pressure is increased, the droplet size decreases and the rate of orifice wear increases.

The values given in the tabulation sections of this catalog indicate the most commonly used pressure ranges for the associated spray tips. When information on the performance of spray tips outside of the pressure range given in this catalog is required, contact the Agricultural Division at Spraying Systems Company®.

Spray Angle and Coverage

Depending on the nozzle type and size, the operating pressure can have a significant effect on spray angle and quality of spray distribution. As shown here for an 11002 flat spray tip, lowering the pressure results in a smaller spray angle and a significant reduction in spray coverage.

Tabulations for spray tips in this catalog are based on spraying water. Generally, liquids more viscous than water form relatively smaller spray angles, while liquids with surface tensions lower than water will produce wider spray angles. In situations where the uniformity of spray distribution is important, be careful to operate your spray tips within the proper pressure range.

Note: Suggested minimum spray heights for broadcast spraying are based upon nozzles spraying water at the rated spray angle.

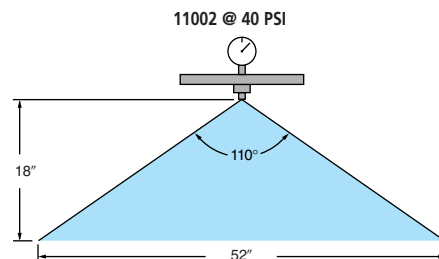
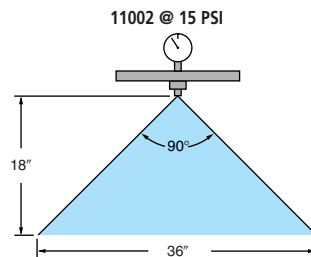
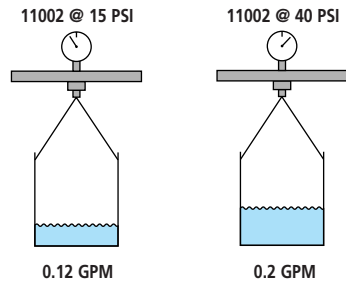

Pressure Drop Through Sprayer Components

Component Number	Typical Pressure Drop (PSI) at Various Flow Rates (GPM)								
	3 GPM	5 GPM	7 GPM	8 GPM	9 GPM	10 GPM	15 GPM	18 GPM	32 GPM
AA2 GunJet®	2.0	5.3	10.0		16.0				
AA18 GunJet	5.0	13.0	25.0		40.0				
AA30L GunJet		14.0							
AA43 GunJet		1.0	2.0						
AA143 GunJet		0.9	1.7			3.5	7.9		
AA6B Valve		0.5	1.2	1.7	2.2	2.9	7.8	12.2	
AA17 Valve		1.5	2.5	3.5	4.0	5.0	11.5	16.0	
AA144A Valve		1.5	2.5	3.5	4.0	5.0	11.5	16.0	
AA144A-1-3 Valve				5.0					
AA145 Valve								5.0	
AA344AE-2 Valve									5.0

Pressure Drop Through Various Hose Sizes

Flow in GPM	Pressure Drop in PSI (10 Ft. length without couplings)				
	1/4" I.D.	3/8" I.D.	1/2" I.D.	3/4" I.D.	1" I.D.
0.5	1.4	.2			
1.0		.7			
1.5		1.4	.4		
2.0		2.4	.6		
2.5		3.4	.9		
3.0			1.2		
4.0			2.0		
5.0			2.9	.4	
6.0			4.0	.6	
8.0				.9	.3
10.0				1.4	.4

Flat Fan and Flood Tip Charts

LFR, RF, DURA-JET CAPACITY CHART

Nozzle Tip Number	Pressure (psig)	Capacity 1-Nozzle (GPIM)	Capacity 1-Nozzle (oz/mn)	20" Spacing Gallons per Acre (GPA) Based on Water					30" Spacing Gallons per Acre (GPA) Based on Water				
				4 MPH	5 MPH	6 MPH	7.5 MPH	10 MPH	4 MPH	5 MPH	6 MPH	7.5 MPH	10 MPH
ISO Color													
65 -.67 80 -.67R 110 -.67R (100 mesh) BR, SS, TH	15	.041	5.2	3.0	2.4	2.0	1.6	1.2					
	20	.047	6.0	3.5	2.8	2.3	1.9	1.4					
	25	.053	6.8	3.9	3.1	2.6	2.1	1.6					
	30	.058	7.4	4.3	3.4	2.9	2.3	1.7					
	40	.067	8.6	5.0	4.0	3.3	2.7	2.0					
	50	.075	7.3	5.6	4.4	3.7	3.0	2.2					
65 - 1 80 - 1R 110 - 1R (100 mesh) BR, SS, TH, RF1	15	.061	7.8	4.5	3.6	3.0	2.4	1.8					
	20	.071	9.0	5.3	4.2	3.5	2.8	2.1					
	25	.079	10.1	5.9	4.7	3.9	3.1	2.3					
	30	.087	11.1	6.4	5.1	4.3	3.4	2.6					
	40	.10	12.8	7.4	5.9	4.9	4.0	3.0					
	50	.11	14.1	8.3	6.6	5.5	4.4	3.3					
80 - 1.5R 110 - 1.5R (100 mesh) BR, SS, TH, RF1.5	15	.092	11.7	6.8	5.5	4.5	3.6	2.7	4.6	3.6	3.0	2.4	1.8
	20	.11	14.1	7.9	6.3	5.3	4.2	3.2	5.4	4.4	3.6	2.9	2.2
	25	.12	15.4	8.8	7.0	5.9	4.7	3.5	5.9	4.8	4.0	3.2	2.4
	30	.13	16.6	9.6	7.7	6.4	5.1	3.9	6.4	5.1	4.3	3.4	2.6
	40	.15	19.2	11.1	8.9	7.4	5.9	4.5	7.4	5.9	5.0	4.0	3.0
	50	.17	21.8	12.5	10.0	8.3	6.6	5.0	8.4	6.7	5.6	4.5	3.4
ISO	60	.18	23.0	13.6	10.9	9.1	7.3	5.5	8.9	7.1	5.9	4.8	3.6
80 2R 110 - 2R (50 mesh) BR, SS, TH, RF2	15	.12	15.4	9.1	7.3	6.1	4.8	3.6	5.9	4.8	4.0	3.2	2.4
	20	.14	17.9	10.5	8.4	7.0	5.6	4.2	7.0	5.6	4.7	3.7	2.8
	25	.16	20.5	11.7	9.4	7.8	6.3	4.7	7.9	6.3	5.3	4.2	3.2
	30	.17	21.8	12.9	10.3	8.6	6.9	5.1	8.6	6.9	5.7	4.6	3.4
	40	.20	25.6	14.8	11.9	9.9	7.9	5.9	9.9	7.9	6.6	5.3	4.0
	50	.22	28.2	16.6	13.3	11.1	8.9	6.6	11.1	8.9	7.4	5.9	4.4
ISO	60	.24	30.7	18.2	14.5	12.1	9.7	7.3	12.1	9.7	8.1	6.5	4.8
80 - 3R 110 - 3R (50 mesh) BR, SS, TH, RF3	15	.18	23.6	13.5	10.9	9.1	7.3	5.5	8.9	7.1	5.9	4.8	3.6
	20	.21	26.8	15.8	12.6	10.5	8.4	6.3	10.4	8.3	6.9	5.5	4.2
	25	.24	31.7	17.6	14.1	11.7	9.4	7.0	12.1	9.7	8.1	6.5	4.8
	30	.26	33.3	19.3	15.4	12.9	10.3	7.7	12.9	10.3	8.6	6.9	5.1
	40	.30	38.4	22	17.8	14.9	11.9	8.9	14.8	11.9	9.9	7.9	5.9
	50	.34	43.5	25	19.9	16.6	13.3	10.0	16.8	13.5	11.2	9.0	6.7
ISO	60	.37	47.4	27	22	18.2	14.5	10.9	18.3	14.6	12.2	9.8	7.3
80 - 4R 110 - 4R (50 mesh) BR, SS, TH, RF4	15	.24	30.7	18.2	14.5	12.1	9.7	7.3	12.1	9.7	8.1	6.5	4.8
	20	.28	35.8	21	16.8	14.0	11.2	8.4	14.0	11.2	9.3	7.5	5.6
	25	.32	41.0	23	18.8	15.7	12.5	9.4	15.8	12.7	10.6	8.4	6.3
	30	.35	44.8	26	21	17.1	13.7	10.3	17.1	13.7	11.4	9.1	6.9
	40	.40	51.2	30	24	19.8	15.8	11.9	19.8	15.8	13.2	10.6	7.9
	50	.45	57.6	33	27	22	17.7	13.3	22	17.7	14.8	11.8	8.9

ISO	60	.49	62.7	36	29	24	19.4	14.5	24	19.4	16.2	12.9	9.7	
80 - 5R 110 - 5R (50 mesh) BR, SS, TH, RF5	15	.31	39.7	23	18.2	15.2	12.1	9.1	15.3	12.3	10.2	8.2	6.1	
	20	.35	44.8	26	11	17.5	14.0	10.5	17.5	14	11.7	9.3	7.0	
	25	.40	51.2	29	23	19.6	15.7	11.7	19.8	15.8	13.2	10.6	7.9	
	30	.43	55.0	32	26	21	17.1	12.9	21	17.1	14.3	11.4	8.6	
	40	.50	64.0	37	30	25	19.8	14.9	25	19.8	16.5	13.2	9.9	
	50	.56	71.7	42	33	28	22	16.6	28	22	18.4	14.8	11.1	
ISO	60	.61	78.1	45	36	30	24	18.2	30	24	20	16.2	12.1	
80 - 6R 110 - 6R (50 mesh) BR, SS, TH, RF6	15	.37	47.4	27	22	18.2	14.5	10.9	18.3	14.6	12.2	9.8	7.3	
	20	.42	53.8	32	25	21	16.8	12.6	21	16.8	14.0	11.2	8.4	
	25	.47	60.2	35	28	23	18.8	14.1	23	18.6	15.5	12.4	9.3	
	30	.52	66.6	39	31	26	21	15.4	26	21	17.1	13.7	10.3	
	40	.60	76.8	45	36	30	24	17.8	30	24	19.8	15.8	11.9	
	50	.67	85.8	50	40	33	27	19.9	33	27	22	17.1	13.3	
ISO	60	.73	93.4	55	44	36	29	22	36	29	24	19.4	14.5	
80 - 8R 110 - 8R (50 mesh) BR, SS, TH, RF8	15	.49	62.7	36	29	24	19.4	14.5	24	19.4	16.2	12.9	9.7	
	20	.57	73.0	42	34	28	22	16.8	28	22	18.7	14.9	11.2	
	25	.63	80.6	47	38	31	25	18.8	31	25	21	16.6	12.5	
	30	.69	88.3	51	41	34	27	21	34	27	23	18.3	13.7	
	40	.80	102.4	59	48	40	32	24	40	32	26	21	15.8	
	50	.89	113.9	66	53	44	35	27	44	35	30	24	17.7	
ISO	60	.98	125.4	73	58	48	39	29	48	39	32	26	19.4	
80 - 10R 110 - 10R BR, SS, TH	15	.61	78.1	45	36	30	24	18.2	30	24	20	16.2	12.1	
	20	.71	90.8	53	42	35	28	21	35	28	23	18.7	14.0	
	25	.79	101.1	59	47	39	31	23	39	31	26	21	15.6	
	30	.87	111.4	64	51	43	34	26	43	34	29	23	17.1	
	40	1.0	128.0	75	59	50	40	30	50	40	33	26	19.8	
	50	1.1	140.8	83	66	55	44	33	55	44	37	30	22	
80 - 15R 110 - 15R BR, SS, TH	60	1.2	153.6	91	73	61	48	36	61	48	40	32	24	
	15	.92	117.8	68	55	45	36	27	46	36	30	24	18.2	
	20	1.1	140.8	79	63	53	42	32	53	42	35	28	21	
	25	1.2	153.6	88	70	59	47	35	59	48	40	32	24	
	30	1.3	166.4	96	77	64	51	39	64	51	43	34	26	
	40	1.5	192.0	111	89	74	59	45	74	59	50	40	30	
	50	1.7	217.6	125	100	83	66	50	83	66	55	44	33	
60	1.8	230.4	136	109	91	73	55	91	73	61	48	36		
80 - 20R 110 - 20R BR, SS, TH	15	1.2	153.6	91	73	61	48	36	60	48	40	32.4	24.2	
	20	1.4	179.2	105	84	70	56	42	70	56	46	37.4	28	
	25	1.6	204.8	117	94	78	63	47	78	61	52	42	31.2	
	30	1.7	217.6	129	103	86	69	51	86	68	58	46	24.2	
	40	2.0	256.0	149	119	99	79	59	100	80	66	52	39.6	
	50	2.2	281.6	166	133	111	89	66	110	88	74	60	44	
60	2.4	307.2	182	145	121	97	73	122	96	80	62	48		

F & D Nozzles Capacity Chart

		GALLONS PER ACRE (GPA) - BASED ON WATER																
Nozzle Tip Number	Pressure (psig)	Capacity (gpim) 1 Nozz.	30" Spacing					40" Spacing					60" Spacing					
ISO Color			4 MPH	5 MPH	6 MPH	10 MPH	15 MPH	4 MPH	5 MPH	6 MPH	10 MPH	15 MPH	4 MPH	5 MPH	6 MPH	10 MPH	15 MPH	18 MPH
D.75 F.75	10	.075	3.7	3.0	2.5	1.5	.99	2.8	2.2	1.9	1.1	7.4	1.9	1.5	1.2	.74	.50	.41
	20	.11	5.3	4.2	3.5	2.1	1.4	3.9	3.3	2.6	1.6	1.1	2.6	2.2	1.8	1.1	.70	.58
	30	.13	6.4	5.1	4.3	2.6	1.7	4.8	3.9	3.2	1.9	1.3	3.2	2.6	2.1	1.3	.86	.71
	40	.15	7.4	5.9	5.0	3.0	2.0	5.6	4.5	3.7	2.2	1.5	3.8	3.0	2.5	1.5	.99	.82
D 1 F 1	10	.10	4.9	4.0	3.3	2.0	1.3	3.7	3.0	2.5	1.5	.99	2.4	2.0	1.6	1.0	.66	.55
	20	.14	7.0	5.6	4.7	2.8	1.9	5.3	4.2	3.5	2.1	1.4	3.6	2.8	2.3	1.4	.93	.78
	30	.17	8.6	6.9	5.7	3.4	2.3	6.4	5.1	4.3	2.6	1.7	4.2	3.4	2.9	1.7	1.1	.95
	40	.20	9.9	7.9	6.6	4.0	2.6	7.4	5.9	5.0	3.0	2.0	5.0	4.0	3.3	2.0	1.3	1.1
D 1.5 F 1.5	10	.15	7.4	5.9	5.0	3.0	2.0	5.6	4.5	3.7	2.2	1.5	3.8	3.0	2.5	1.5	.99	.82
	20	.21	10.5	8.4	7.0	4.2	2.8	7.9	6.3	5.3	3.2	2.1	5.2	4.2	3.5	2.2	1.4	1.2
	30	.26	12.9	10.3	8.6	5.1	3.4	9.6	7.7	6.4	3.9	2.6	6.4	5.2	4.3	2.6	1.7	1.4
	40	.30	14.9	11.9	9.9	5.9	4.0	11.1	8.9	7.4	4.5	3.0	7.4	6.0	5.0	3.0	2.0	1.6
D 2 F 2	10	.20	9.9	7.9	6.6	4.0	2.6	7.4	5.9	5.0	3.0	2.0	5.0	4.0	3.3	2.0	1.3	1.1
	20	.28	14.0	11.2	9.3	5.6	3.7	10.5	8.4	7.0	4.2	2.8	7.0	5.6	4.7	2.8	1.9	1.6
	30	.25	17.1	13.7	11.4	6.9	4.6	12.9	10.3	8.6	5.1	3.4	8.6	6.8	5.7	3.4	2.3	2.4
ISO	40	.40	19.8	15.8	13.2	7.9	5.3	14.8	11.9	9.8	5.9	4.0	9.8	8.0	6.6	4.0	2.6	2.8
D2.5 F2.5	10	.25	12.4	9.9	8.3	5.0	3.3	9.3	7.4	6.2	3.7	2.5	6.2	5.0	4.1	2.4	1.7	1.4
	20	.25	17.3	14.0	11.7	7.0	4.7	13.1	10.5	8.8	5.3	3.5	8.8	7.0	5.8	3.6	2.3	1.6
	30	.43	21	17.1	14.3	8.6	5.7	16.1	12.9	10.8	6.4	4.3	10.8	8.6	7.1	4.2	2.9	2.4
ISO	40	.50	25	19.8	16.5	9.9	6.6	18.6	14.8	12.4	7.4	5.0	12.4	10.0	8.2	5.0	3.3	2.8
D2.5 F2.5	10	.30	14.9	11.9	9.9	5.9	4.0	11.1	8.9	7.4	4.5	3.0	7.4	6.0	5.0	3.0	2.0	1.6
	20	.42	21	16.8	14.0	8.4	5.6	15.5	12.6	10.6	6.3	4.2	10.6	8.4	7.0	4.2	2.8	2.3
	30	.52	26	21	17.1	10.3	6.9	19.3	15.4	12.8	7.7	5.1	12.8	10.2	8.6	5.2	3.4	2.9
ISO	40	.60	30	24	19.8	11.9	7.9	22	17.8	14.8	8.9	5.9	14.8	11.8	9.9	6.0	4.0	3.3
D 2.5 F 2.5	10	.40	19.8	15.8	13.2	7.9	5.3	14.8	11.9	9.8	5.9	4.0	9.8	8.0	6.6	4.0	2.6	2.2
	20	.57	28	22	18.7	11.2	7.5	21	16.8	14.0	8.4	5.6	14.0	11.2	9.3	5.6	3.7	3.1
	30	.69	34	27	23	13.7	9.1	26	20	17.2	10.3	6.9	17.2	13.8	11.4	6.8	4.6	3.8
ISO	40	.80	40	32	26	15.8	10.6	30	24	19.8	11.9	7.9	19.8	15.8	13.2	8.0	5.3	4.4
D 5 F 5	10	.50	25	19.8	16.5	9.9	6.6	18.6	14.9	12.4	7.4	5.0	12.4	10.0	8.2	5.0	3.3	2.8
	20	.71	35	28	23	14.0	9.3	26	21	17.6	10.5	7.0	17.6	14.0	11.7	7.0	4.7	3.9
	30	.87	43	34	29	17.1	11.4	32	26	21	12.9	8.6	21	17.2	14.3	8.6	5.7	4.8
	40	1.0	50	40	33	19.8	13.2	37	30	25	14.9	9.9	25	19.8	16.5	10.0	6.6	5.5
D 6	10	.60	30	24	19.8	11.9	7.9	22	17.8	14.8	8.9	5.9	14.8	11.8	9.9	6.0	4.0	3.3
	20	.85	42	34	28	16.8	11.2	32	25	21	12.6	8.4	21	16.8	14	8.4	5.6	4.7
	30	1.0	51	41	34	21	13.7	39	31	26	15.4	10.3	26	21	17.1	10.2	6.9	5.7
	40	1.2	59	48	40	24	15.8	45	36	30	17.8	11.9	30	24	19.8	11.8	7.9	6.6
D 7.5 F 7.5	10	.75	37	30	25	14.9	9.9	28	22	18.6	11.1	7.4	18.6	14.8	12.4	7.4	5.0	4.1
	20	1.1	53	42	35	21	14.0	39	32	26	15.8	10.5	26	21	17.5	10.6	7.0	5.8
	30	1.3	64	51	43	26	17.1	48	39	32	19.3	12.9	32	26	21	12.8	8.6	7.4
	40	1.5	74	59	50	30	19.8	56	45	37	23	14.8	37	30	25	14.8	9.9	8.2
D 15 F 15	10	1.0	50	40	33	19.8	13.2	37	30	25	14.9	9.9	24.8	19.8	16.5	10.0	6.6	5.5

F 15 QC RFLD 15	20	1.4	70	56	47	28	18.7	53	42	35	21	14.0	35	28	23	14.0	9.3	7.8
	30	1.7	86	69	57	34	23	64	51	43	26	17.1	42	34	29	17.2	11.4	9.5
	40	2.0	99	79	66	40	26	74	59	50	30	19.8	50	40	33	19.8	13.2	11.0
D15 F 15 QC RFLD 15	10	1.5	74	59	50	30	19.8	56	45	37	23	14.8	37	30	25	14.8	9.9	8.2
	20	2.1	105	84	70	42	28	79	63	53	32	21	52	42	35	21	14.0	11.7
	30	2.6	129	103	86	51	34	96	77	64	39	26	64	52	43	26	17.1	14.3
	40	3.0	149	119	99	59	40	111	89	74	45	30	74	60	50	30	19.8	16.5
D20	10	2.0	99	79	66	40	26	74	59	50	30	19.8	50	40	33	19.8	13.2	11.0
	20	2.8	140	112	93	56	37	105	84	70	42	28	70	56	47	28	18.7	15.6
	30	3.5	171	137	114	69	46	128	103	86	51	34	86	68	57	34	23	19.1
	40	4.0	198	158	132	79	53	148	119	99	59	40	98	80	66	40	26	22

The Remcor Sprayer logo and all pictures of Remcor sprayers are ©2006 Remcor, Inc. Tip Charts obtained from Delavan AgSpray, Spraying Systems, and Hamilton.